

863004ALF	NOTE 1
863004ATLF	NOTE 2
LEAD FREE PART NUMBER	RoHS NOTE

NOTES

Pieces assembly
 Packaging : per 100 piece
 Material : steel

NOTE1:RoHS INFORMATIONS

- The "LF" product meets European union Directives and other country regulations as described in GS-22-008.
- The product is not intended to be exposed to a manufacturing solder process.
- Plating: Zinc Cr3+, white color.
- Packaging spec: see GS-14-920.

NOTE2:RoHS INFORMATIONS

- The "LF" product meets European union Directives and other country regulations as described in GS-22-008.
- The product is not intended to be exposed to a manufacturing solder process.
- Plating: Sn pure bright over Copper.
- Packaging spec: see GS-14-920.

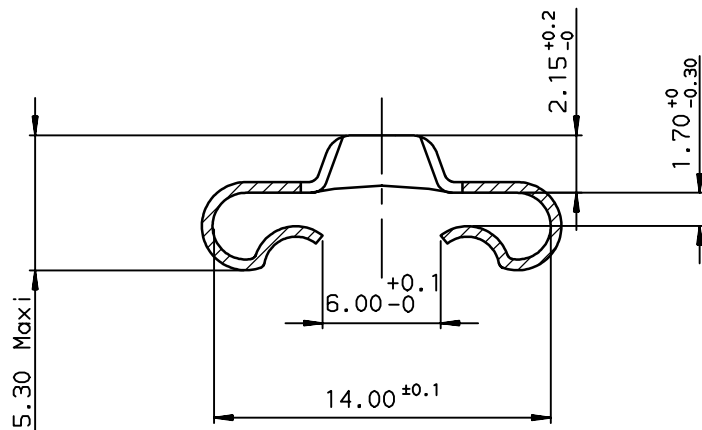

European Views

www.fciconnect.com		surface ISO 1302	<input checked="" type="checkbox"/>	tolerance std ISO 406 ISO 1101	projection 	mm	
TOLERANCES UNLESS OTHERWISE SPECIFIED							
Dr	GOISNARD	2005/12/28	ANGULAR	0.X	±0.1	size	
Eng	PESSON	2005/12/28	LINEAR	0.XX	±0.1	A3	
Chr	LEGARE	2005/12/28	0.XX' ±2'	0.XXX	±0.1	Scale	
Appr	LEGARE	2005/12/28	Product family	D-SUB		5	
-						ECN	LS06-0097
-						Spec ref	-
-						Rev.	B
-						dwg no	C01-8655-1634
-						catalog no	CUSTOMER sheet 1 of 1

rev	ecn no	dr	date
A	LS05-0123	LGO	2005/12/28
B	LS06-0097	LGO	2006/07/28
-	-	-	-
-	-	-	-
-	-	-	-
-	-	-	-



MALE SCREW LOCKS

Copyright FCI. FCI